

Angular wear plate
Eckig Druckplatte

PIASTRINE DI SCORRIMENTO ANGOLARE

Materiale: acciaio 1.8550
Material: steel 1.8550
Werkstoff: stahl 1.8550

Durezza: Hrc 62
Hardness:
Härte:

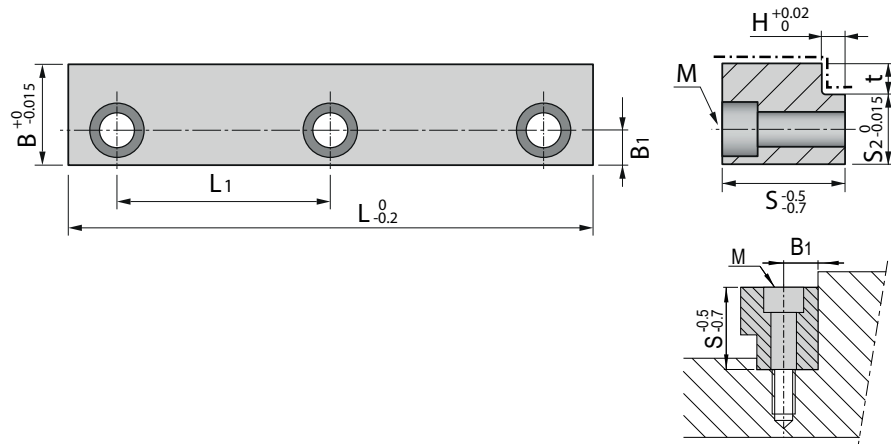

S	S2	H	L	L1	B	B1	M	t	fori holes	
12	9	7	40	24	12	5	M4 DIN 7984	3	2	
			50	34					2	
			63	47					2	
12	12	6	40	24	16	6	M5	4	2	
			50	34					2	
			63	47					2	
14	9	9	40	24	12	5	M4 DIN 7984	3	2	
			50	34					2	
			63	47					2	
16	9	10	40	24	12	5	M4	3	2	
			50	34					2	
			63	47					2	
	11	8	8	50	34	16	6	M5	5	2
				63	47					2
				80	32					3
	12	10	10	40	24	16	6	M5	4	2
				50	34					2
				63	47					2
20	11	12	50	34	16	6	M5	5	2	
			63	47					2	
			80	32					3	
	15	8	8	63	43	20	9	M6	5	2
				80	60					2
				100	40					3
	15	11	11	125	52,5	20	9	M6	5	3
				63	43					2
				80	60					2
24	15	12	100	40	20	9	M6	5	2	
			80	60					2	
			100	40					3	

S	S2	H	L	L1	B	B1	M	t	fori holes	
25	15	8	80	60	20	9	M6	5	2	
			100	40					3	
			125	52,5					3	
25	15	13	80	60	20	9	M6	5	2	
			100	40					3	
			125	52,5					3	
29	15	12	80	60	20	9	M6	5	2	
			100	40					3	
			160	70					3	
32	19	10	100	76	25	11	M8	6	2	
			125	50,5					3	
			160	68					3	
	19	16	16	200	58	25	11	M8	6	4
100				76	2					
125				50,5	3					
37	19	15	100	76	25	11	M8	6	2	
			125	50,5					3	
			160	68					3	
40	19	10	200	58	25	11	M8	6	4	
			250	74					4	
			125	50,5					3	
	19	16	16	160	68	25	11	M8	6	3
				200	58					4
250				74	4					
50	24	12	160	64	32	14	M10	8	3	
			200	84					3	
			250	72					4	
	24	20	20	315	93	32	14	M10	8	4
				160	64					3
				200	84					3
24	20	20	250	72	32	14	M10	8	4	
			315	93					4	

Esempio d'ordine: T3117 = S x S2 x H x L
Order example:
Bestellbeispiel:

ACCESSORI PER STAMPI
Accessories for mould
Zubehör für mould