

Materiale: bronzo e grafite
Material: bronze graphite
Werkstoff: bronze graphit

Durezza: HB 210÷240
Hardness:
Härte:

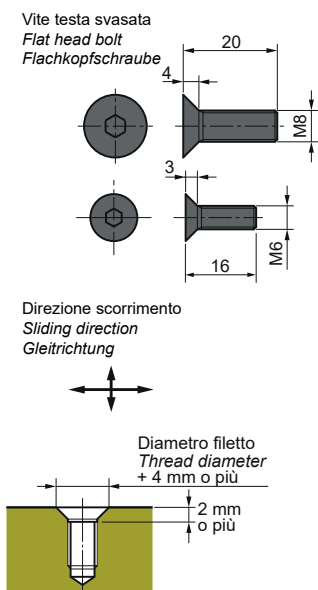

W= da 18 a 38 L= da 50 a 100
W= 48 L= da 75 a 125

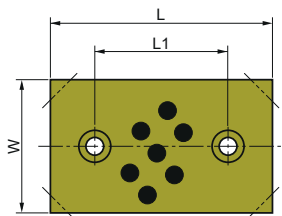

W= 75 L= da 75 a 125
W= 100 L= da 100 a 125

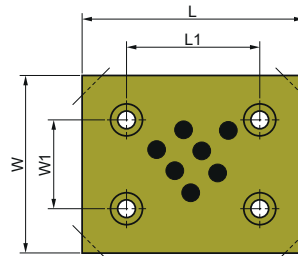

W= da 18 a 48 L= 150

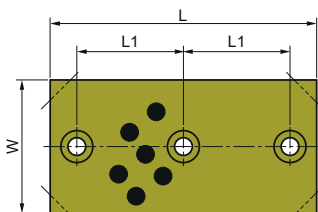

W= 75 e 100 L= 150

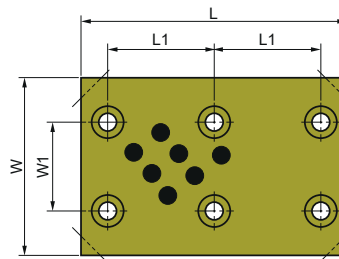

W	L	W1	L1	d	h	Viti Mounting bolt
18	50	-	20	6,5	1,5	M6
	75		45			
	100		70			
	150		60			
28	50	-	20	10	0,8	M8
	75		45			
	100		70			
	150		60			
38	50	-	20	10	0,8	M8
	75		45			
	100		70			
	150		60			
48	75	-	45	10	0,8	M8
	100		70			
	125		95			
	150		60			
75	75	45	45	10	0,8	M8
	100		70			
	125		95			
	150		60			
100	100	70	70	10	0,8	M8
	125		95			
	150		60			

Esempio d'ordine: UWP = W x L

Order example:

Bestellbeispiel: