

CARRELLO TIPO "KOCU-S"

N.	Descrizione / description	Q.tà Q.ty	Materiale / material
1	Base a slitta / Slide base	1	S45C Tufftrid ("I" C45 "A" 1045)
2	Piastra superiore / Upper Plate	2	S45C Tufftrid ("I" C45 "A" 1045)
3	Supporto del perno / Pin Holder	1	S45C Tufftrid ("I" C45 "A" 1045)
4	Piastra di scorrimento / Slide plate	2	Bronzo con grafite / Bronze with graphite (SO#50 SP2)
5	Vite a testa piatta / Socket head screw	1	SCM435 (Special) ("I" 34CrMo4 "A" 4137)
6	Vite a testa piatta / Socket head screw	4	SCM435 (Special) ("I" 34CrMo4 "A" 4137)

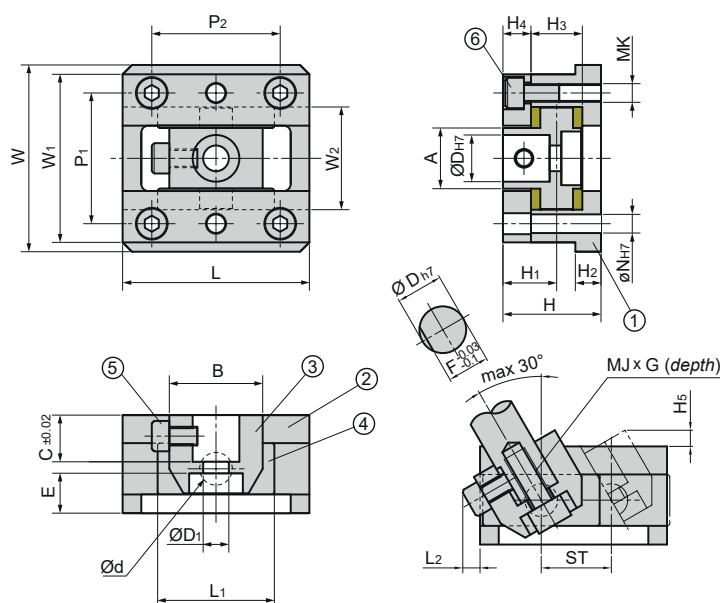

Tolleranza non specificata
Tolerance not specified: DIN ISO 2768 - middle

D	d	D1	A	B	C	E	F	MJ	G	H	H1	H2	H3	H4	H5	L	L1	L2	W	W1	W2	P1	P2	MK	N	ST
8	7	4,5	11	20	8	10	7	M4	8	22	12,5	5	11	7	10,5	32	20	3,6	33	30	19	24	20	M3	3	10
10	7	5,5	15	25	10	12,5	9	M5	9	27	15,5	5	15	8	11,3	45	25	4,5	45	40	25	32	30	M4	4	18
12	10	7	17	25	12	15	11	M6	10	32	18	7	16	10	4	50	30	5	57	51	31	39	35	M6	6	20
16	12	9	22	30	16	15	14,5	M8	12	36	20	8	20	10	5	65	40	5	65	58	38	46	40	M6	6	25
20	14	11	26	40	20	16	18	M10	16	42	23	11	22	12	8	80	50	5	80	72	44	56	55	M8	8	30
25	16	14	32	45	25	17	22,5	M12	20	50	28	15	26	15	8	90	55	6	93	85	52	66	65	M10	10	35
30	18	14	38	50	30	17	27	M12	25	55	30	15	30	15	9	100	60	7	101	93	60	74	70	M10	10	40
35	20	14	45	60	35	18	32	M12	30	62	35	15	34	18	10	120	75	8	120	110	70	85	80	M12	10	45
40	25	18	55	70	40	19	36	M16	35	70	40	15	44	18	12	135	85	8	130	120	80	95	90	M12	10	50
45	30	18	60	80	45	24	40	M16	40	80	45	15	50	20	14	150	95	10	140	130	90	105	110	M12	10	55

Esempio d'ordine: KOCU-S = D

Order example:

Bestellbeispiel: