

Oilles slide unit for loose core "F" type "KOCU-F"
Bolzenführung typ "KOCU-F"



KOCU-F

Giu 2023

CARRELLO TIPO "KOCU-F"

N.	Descrizione / description	Q.tà Q.ty	Materiale / material
1	Boccola di guida / Guide rail	2	C45
2	Supporto del perno inclinato / Inclined pin holder	1	C45
3	Piastra di scorrimento / Slide plate	2	Bronzo con grafite / Bronze with graphite
4	Blocco allentamento / Loosening lock	1	Acciaio / Steel
5	Piastra di blocco / Lock plate	2	Ferro / Iron
6	Vite a testa bombata / Round head screw	4	34CrMo4

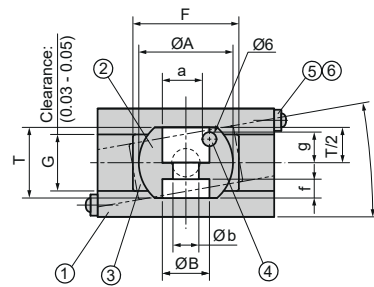
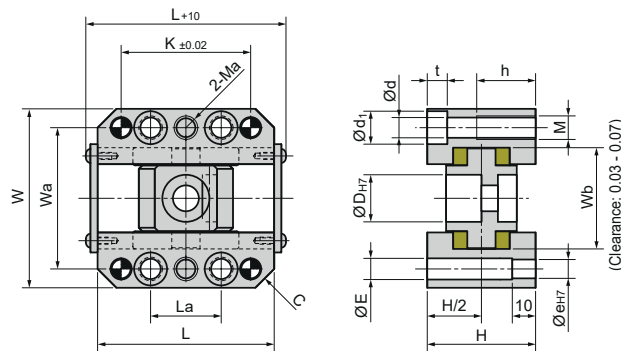

* Rimuovere ⑤ piastra di bloccaggio come richiesto per il funzionamento
* Remove ⑤ lock plate as required for operation.

D	r	W	Wa	L	La	K	Ma	C	H	e	E	d	d1	t	h	M	Wb	A	a	B	b	g	F	f	G	T
8	0° ~ 10°	41	33	44	12	25	M4	3	24	4	5	3,4	6	3,4	10	M4	24	20	7,5	10	5	6,5	25	5	13	16
10		47	38	50	16	30	M5	3	28	5	5,5	4,5	8	5	15	M5	28	20	8,5	12	6	6,5	32	4	17	16
12		53	42	60	20	40	M8	4	36	6	7	6,6	11	4,8	20	M8	31	25	10	13	7	8,5	40	5	20	20
16		64	50	70	25	50	M8	6	40	6	6,6	6,6	11	6,5	20	M8	36	30	13	16	9	10	45	6	24	24
20		76	60	75	30	55	M10	8	46	8	9	8,6	14	8,5	25	M10	43	40	17	20	11	13	45	8	24	30
25		81	65	85	40	65	M10	8	48	8	9	8,6	14	8,5	25	M10	48	45	22	25	14	14	50	9,5	26	35
30		88	72	100	50	80	M10	8	54	8	9	8,6	14	8,5	25	M10	55	50	27	25	14	15	60	9	30	38
35		100	80	115	50	85	M12	8	60	10	11	11	18	6,5	30	M12	64	55	31	25	14	15	70	10	34	40
40	108	88	125	50	85	M12	8	65	10	11	11	18	7	30	M12	72	60	36	32	18	16	80	11,5	38	43	

Esempio d'ordine: KOCU-F = D x r
Order example:
Bestellbeispiel:

Fornibili anche con gradi (r) da 11° a 20°
Also available degrees (r) 11°~ 20°
Auch mit Graden erhältlich (r) 11°~ 20°

BRONZO E GRAFITE
Bronze graphite
Bronze graphit