

DATARI PER PRESSOFUSIONE

Materiale: acciaio 1.2343

Material: steel 1.2343

Werkstoff: stahl 1.2343

Durezza: Hrc 44 ± 48

Hardness:

Härte:

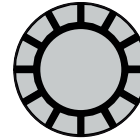
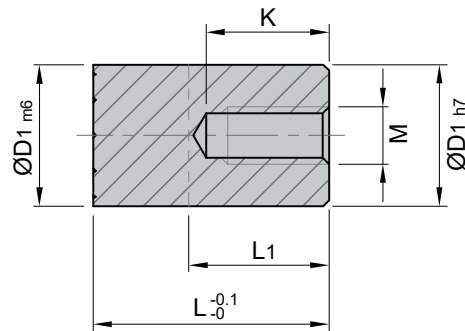

D1	L	L1	M	K
5	10	6	3	6
6	10	6	4	6
8	10	6	4	6
	20	10	3	6
10	12	7	5	6
	20	10	4	7,5
12	14	9	6	10
	20	10	6	9
16	20	10	6	10
20	20	10	6	10

Esempio d'ordine: DAP = D1 x L x anno

Order example:

Bestellbeispiel: